

CNS LonWorks® Serial Gateway

Provisional

Features



- ◆ LonWorks® transceivers type 78Kb/s twisted pair Free topology transceiver (FTT-10A),
- ◆ Din Rail
- ◆ High Speed RS-232/ RS-485 Interface up to 115.2 kbps
- ◆ 24V AC/DC powered
- ◆ LED and service LED's for both sides of the gateway
- ◆ LonMark, LNS compliant
- ◆ CE, RoHS

Description

The Serial Gateway provides a serial interface between RS-232 or RS-485 and LONWORKS networks offering data transfer rates of up to 115.2 kbps. The Neuron chip maps the interface to the LON side.

By default, the unit works with standard software **SPA** (Serial PC Adapter) in FLASH for network access from a PC (Note: not LNS compatible). All received network messages or network variable updates are sent to the PC. Messages from the PC are transferred to the network. The serial transmission is controlled by the SPA-protocol. The PC software library supports receive and

send operations similar to those in Neuron-C. These functions and the underlying data structures make the implementation of network management tools and visualisation software easy. It can be used for connecting PCs, printers, modems, or any other equipment with serial interface to a LonWorks network.

On request we can supply a driver DLL which can be used to create your own Windows applications with Lon access via this Serial Gateway.

The unit is an excellent platform for custom specific programming (including gateway functions or customised protocols) due to the flexible memory configuration (FLASH and RAM) as well as the unlimited access to the serial data lines.

For the implementation of your own proprietary protocols in the firmware, a Neuron-C-library is available under signed license (free of charge).

We also offer a Custom Software engineering service and would be pleased to quote against your Requirement Specification document.

Caution: *Installation by qualified personnel only. Observe established engineering procedures and CNS's published data. Be careful when connecting power!*

Please note that CNS supplies a complete range of Lon Network Infrastructure Products (NIP's) and Internet Lon Network Infrastructure Products (INIP's) including Physical Layer Repeaters, Lon Terminators, LonRouters (inc Fibre), Lon/IP 852 & Lon/ WiFi 852 Routers please visit our web site www.control-network-solutions.co.uk for more information.

For additional information regarding use of these products please, refer to CNS LonWorks Router Guide and CNS LonWorks Din Router Installation Guide. Please note that CNS supplies a complete range of Lon Network Infrastructure Products (NIP's) and Internet Lon Network Infrastructure Products (INIP's) including Physical Layer Repeaters, Lon Terminators, Lon/IP 852 & Lon/ WiFi 852 Routers please visit our web site www.control-network-solutions.co.uk for more information.

Specifications

Mechanical

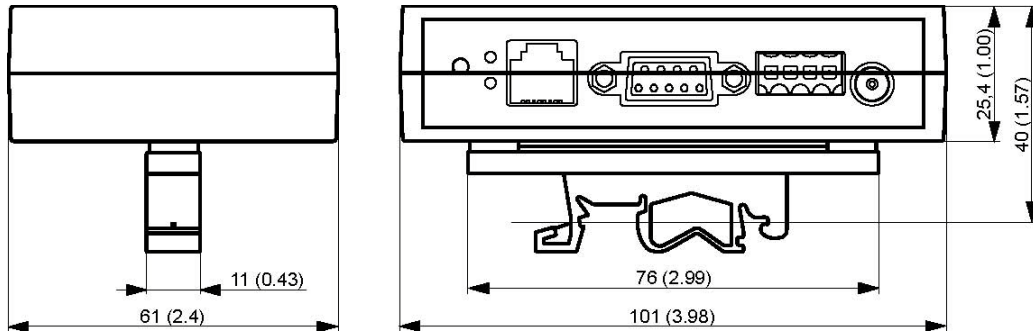

Din mounted Bracket can be fitted to underside of unit. Unit is suitable for fitting on DIN 46277 and DIN EN 50022 mounting rail

Connections and Status LED's

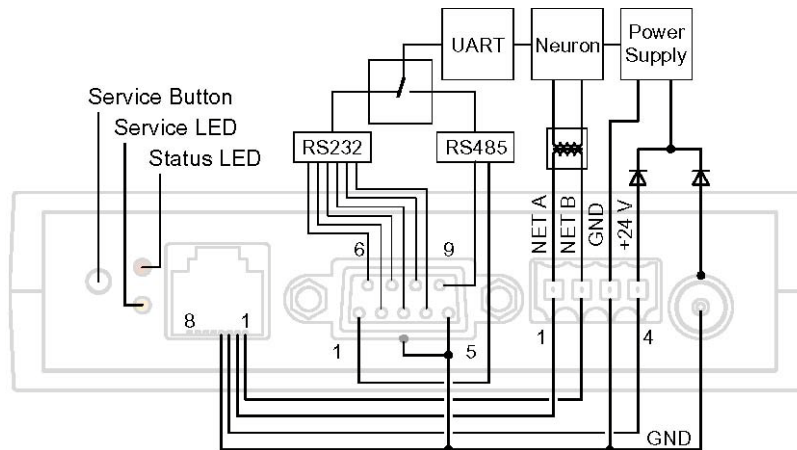

Fig 1

The TP/FT-10 Lon interface is provided via the RJ-45 and 4-pole cage clamp connectors. For more details regarding TP/FT-10 media please refer to the "FT3120/FT3150 Smart Transceiver Data Book" available from the Echelon® Corporation.

Terminal Configuration

LON Port RJ - 45

This device can be supplied with power via the RJ-45 connector (Pins 3 and 4). The Power Jack and RJ-45 power supply paths are decoupled by diodes, but are not galvanically isolated. For pin assignments see “Terminal Assignments” table on the next page.

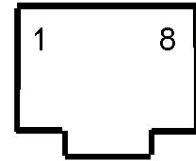

Warning: Use only one power supply path to power the device!

Please observe the guidelines concerning the cable length and recommended cable types, published by Echelon Corporation and the LONMARK Interoperability Association.

Serial Port

Connecting Lon Serial Gateway to a PC

PC connector		Signal	IFMS RS232
25 pin D-sub	9 pin D-sub		9 pin D-sub
3	2	RxD	2
2	3	TxD	3
7	5	GND	5
4	7	RTS (optionally)	7
5	8	CTS (optionally)	8

Note: Potential differences between the ground of the serial connector and the power supply may destroy the device. Avoid potential differences by using a galvanically isolated power supply unit.

Connect Lon Serial Gateway to a Modem

Modem connector		Signal	IFMS RS232
25 pin D-sub	9 pin D-sub		9 pin D-sub
3	2	RxD	2
2	3	TxD	3
7	5	GND	5
4	7	RTS (optionally)	7
5	8	CTS (optionally)	8
6	6	DSR (optionally)	4
8	1	DCD (optionally)	1
20	4	DTR (optionally)	6
22	9	RI (optionally)	9

Terminal Assignments

Terminal		Function	
TP/FT-10, supply - RJ45 connector			
1		LON-Bus TP/FT-10, NET B	
2		LON-Bus TP/FT-10, NET A	
3		+24 V	
4		GND	
5, 6, 7, 8		n.c.	
D-Sub connector female 9 poles			
1	RS232	DCD	input
	RS485	RS485 B / DCD	bidirectional / input
2		TxD	output
3		RxD	input
4		DSR	input
5		GND	
6		DTR	output
7		CTS	input
8		RTS	output
9		RI	input
		RS485 A / RI	bidirectional / input
Dedicated power supply connector (barrel jack, e.g. Lumberg NES/J 21)			
Outside		+24 V	
Inside		GND	
TP/FT-10, power – plug-in cage terminal (to be used alternatively to RJ45)			
1		LON-Bus TP/FT-10, NET A	
2		LON-Bus TP/FT-10, NET B	
3		GND	
4		+24 V	

Serial Port RS-232/485 (D-SUB-9-Jack)

The RS232- and/or RS485 interface is provided by the D-Sub female connector. For connecting the device to a PC with a RS232 extension (male to female, 1:1) or to a Modem with a cable with crossed lines (male to male) cable, at least RxD, TxD and GND are mandatory.

Configuration RS232 / RS485

Default configuration with SPA standard application: 4800 Baud, 8 data bits, No parity and 1 stop bit (4800, 8N1).

Change of configuration in configuration mode (always 4800, 8N1): Connect device with the serial interface of a PC that runs a terminal program (e.g. Windows Hyperterminal, 4800, 8N1). For entering configuration mode press and hold the service button when connecting the device to power supply. An interactive menu will appear that allows changing the serial interface parameters.

For the RS-485 version bus lines are on pins 1 and 9 of the D-sub connector when working in RS-485 mode.

Note: The power supply lines of the RJ45 connector and of the 4-pole connector are not decoupled from each other (see fig 1 above.). The dedicated power supply connector is decoupled from the other power supply connectors by diodes, but not galvanically isolated.

Power Supply Adapter Jack

Barrel Jack for Lumberg NES/J 21

Pin diameter is	1.95 mm
Opening diameter is	6.0 mm
Centre	GND
Outer	24VAC/DC

Note: Exceeding the indicated voltage range can damage the device!

The device can be supplied alternatively via RJ45 connector, 4-pole connector or dedicated power supply connector.

Caution: Installation by qualified personnel only. Observe established engineering procedures and published data.

Terminals	
TP/FT-10 / Supply -RJ45	
Type	RJ45, unshielded
TP/FT-10 / Supply -Cage Clamp	
Type	plug-in cage clamp
Rated cross section	1.5 mm ²
Clamping range	0.08 mm ² to 1.5 mm ² , AWG 26 to AWG 14
Insulation stripping length	10 ⁺¹ mm
RS232	
Type	9 pin D-sub connector female
Supply	
Type	barrel jack, e.g. for Lumberg NES/J 21
Diameter opening/pin	6.0 mm / 1.95 mm

Technical		
Electrical		
Processor	3150 @ 10Mhz	
Memory	32K FLASH + 25KiB SRAM (Other options up to a maximum of 64KiB Flash + 32KiB SRAM available on request)	
Lon Transceiver	FTT10A, (RS-485 available on request)	
Supply	AC	19.2 V to 28.8 V
	DC	10 V to 33 V
Power	≤ 0.6W	
Environmental		
Operating Temp	-40 to +70°C	
Storage Temp	-40...85°C	
Relative Humidity	0 – 75% (annual average non – condensing)	
Rating	IP20	
Packaging		
Weight	110g approx	
Dimensions	101 mm x 25 mm x 61 mm / 3.98 " x 1.00 " x 2.4 "	
Material	ABS 94 HB	
Certification		
CE	EN 55022, class B, EN 61000-4-4, EN 61000-6-2, EN 61000-4-2 , EN 61000-6-2, EN 61000-4-3, EN 61000-6-2, EN 61000-4-6, EN 61000-6-2	

Reference documents for installation and network topology issues;

Echelon LonWorks FTT-10A Transceiver User's Guide, 078-0198-01D

Echelon LPT-11 Link Power Transceiver User's Guide, 078-0198-01A

Echelon Twisted Pair Transceiver User's Guide, 078-0025-01C

FT3120/FT3150 Smart Transceiver Data Book

Ordering Information

Part No. = CNSSGS/2/RS-232/DIN
CNSSGS/2/RS-485/DIN

Contact

Control Network Solutions Ltd

Studio 7,

Intec 2,

Intec Business Park,

Wade Road,

BASINGSTOKE,

Hampshire, RG24 8AG, England

Tel: +44 (0) 1256 818700

Fax: +44 (0) 1256 812520

Email: cns@control-network-solutions.co.uk

Web: www.control-network-solutions.co.uk

No part of this publication may be reproduced or transmitted in any form or by any means, electronic, mechanical, photocopying, recording, in part or in whole, without prior permission of Control Network Solutions. We reserve the right to make changes without notice to any products herein as part of its continued product development and improvements. We do not assume any liability arising out of the application or use of any product or circuit described herein.

Lon, LonWorks, LNS, RTR-10, FTT-10A are all trademarks of Echelon Corporation.