

## Power over Ethernet (PoE) Injector

### Datasheet

#### Features

- ◆ Fully power one Powered Device (PD)
- ◆ Isolated 15.4 W power output
- ◆ 10BASE-T/100BASE-TX compliant
- ◆ Compact Size
- ◆ DIN-rail mountable
- ◆ 24V AC/DC
- ◆ IEEE 802.af compliant
- ◆ Diagnostic LEDs
- ◆ EMC rated for Building and Industrial environments
- ◆ CE Mark and RoHS Compliant



#### Description

The CNSEIPE Power over Ethernet (PoE) Power Injector in the offers a simple method of connecting a single PoE end-device to a non-PoE 10/100 Mbps Ethernet switch. In automation systems, 24 VAC/VDC power is very common and the EIPE accepts this input and internally transforms it to the 48 VDC required for PoE. The CNSEIPE is compliant to the IEEE 802.3af standard and is considered mid-span Power Sourcing Equipment (PSE) that resides between the non-PoE switch and the Powered Device (PD) delivering the required 15.4 watts of power at its output connector. The CNSEIPE is ideal for applications when 48 volt PoE power is unavailable.

The CNSEIPE Power Injector is powered from a 24 VAC or VDC source. This input power requirement eliminates the need for a 48 VDC power supply (and its expense) typically associated with PoE requirements. In many industrial control systems 24 VDC is readily available within the control panel, just like 24 VAC is available at the BAS system. By utilizing the readily available power sources The CNSEIPE internally generates the 48

VDC PoE power eliminating any concerns regarding grounded primary power and supplies it to the Powered Device (PD).

There are two RJ-45 connectors on the unit. The top connector, labelled Ethernet, attaches to the non-PoE switch while the bottom connector, labelled PoE, attaches to the PD. Transmit and receive signals are freely passed between the two connectors as if the injector was not present. However, 48 VDC power is injected into the spare pins on the bottom RJ-45 connector for use by the PD. The injector does not interfere with any communication between the non-PoE switch and the PD.

The Power Injector supports the 802.3af protocol for powering up devices. With the Power Injector powered up, an Ethernet cable is attached to the PD. No power is applied to the PD until a valid 25kΩ resistance called the signature, is sensed by the Power Injector. Once this value is sensed, the Power Injector applies power to the unused pairs thereby powering the PD. Even with total cable length approaching 100 m, the PD can assume that a minimum of 12.95 watts is available at its input pins.

The CNSEIPE utilises a rugged metal enclosure and metal DIN-rail clip for control panel mounting.

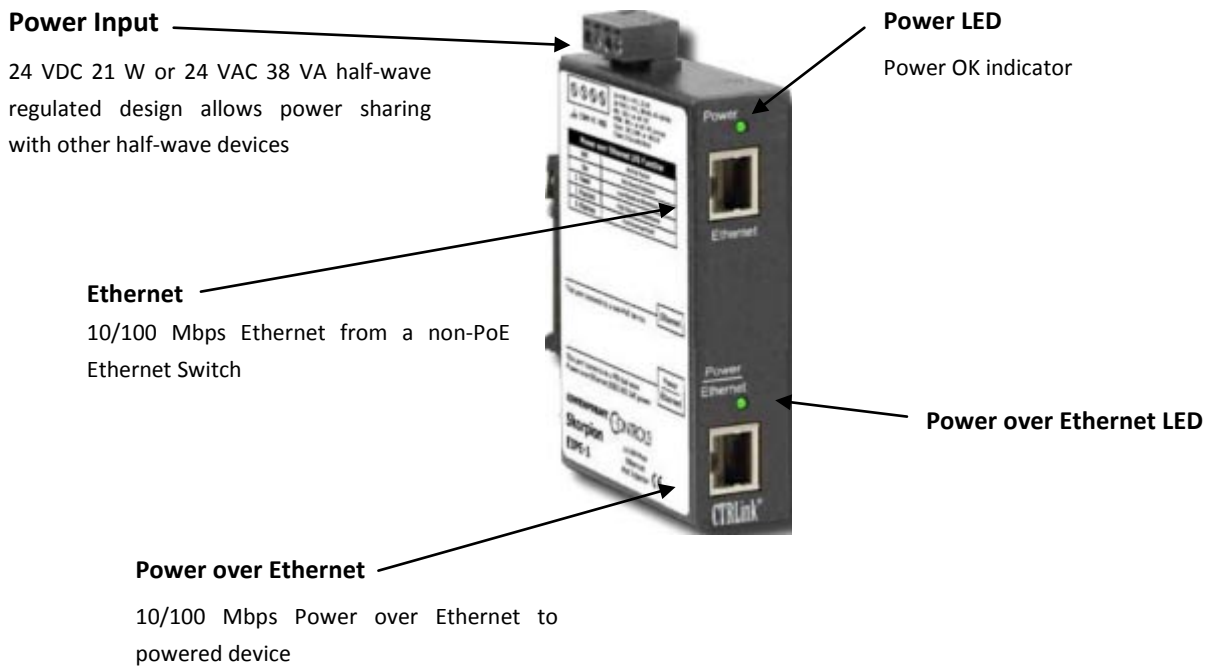

## Specifications

<b>Power Supply</b>	24 VDC $\pm$ 10% 21 W or 24 VAC $\pm$ 10% 38 VA 47–63 Hz
<b>Operating Temperature</b>	0°C to 60°C
<b>Storage Temperature</b>	–40°C to 85°C
<b>Relative Humidity</b>	10–95%, non-condensing
<b>Environmental Protection</b>	IP30
<b>Ethernet Communications</b>	IEEE 802.3 10/100 Mbps data rate 10BASE-T, 100BASE-TX physical layer 100 m (max) CAT5 cable length total for both cables

<b>LEDs</b>	Power	Green = Power OK
	Power over Ethernet	Green = Power being supplied
		Single flash = Low signature resistance
		Two flashes = High signature resistance
		Five flashes = Excessive current
		Off = No power being delivered
<b>Regulatory Compliance</b>	CE Mark; CFR 47, Part 15 Class A; RoHS	

## Ethernet Connector Pin Assignments

Pin	Function
1	Signal 1
2	Signal 2
3	Signal 3
4	N/C
5	N/C
6	Signal 4
7	N/C
8	N/C

## Power over Ethernet Connector Pin assignments

Pin	Function
1	Signal 1
2	Signal 2
3	Signal 3
4	+ 48 VDC
5	+ 48 VDC
6	Signal 4
7	48 VDC return
8	48 VDC return

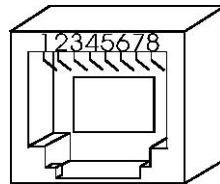

## Mechanical

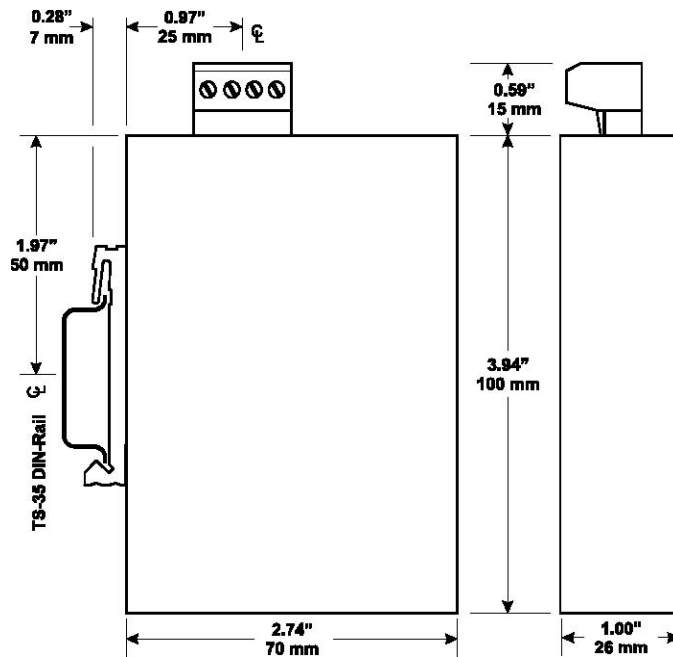

## Power Input and Output Circuitry

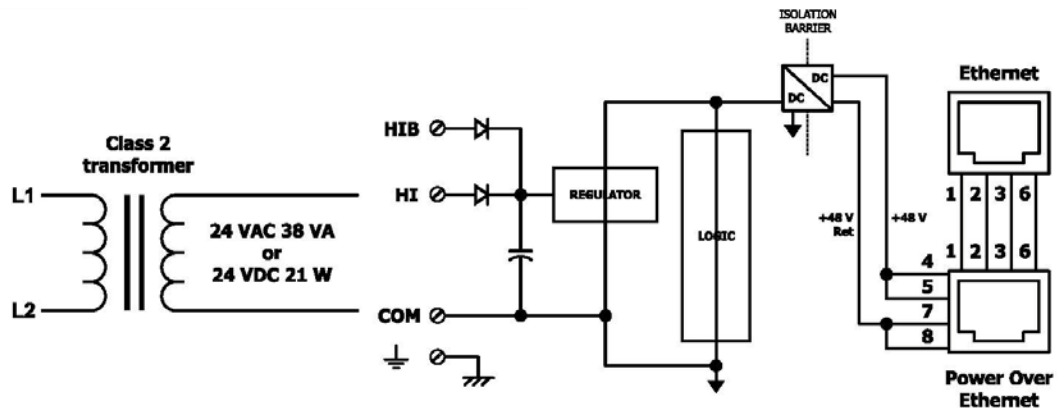

## Typical Application Scenarios

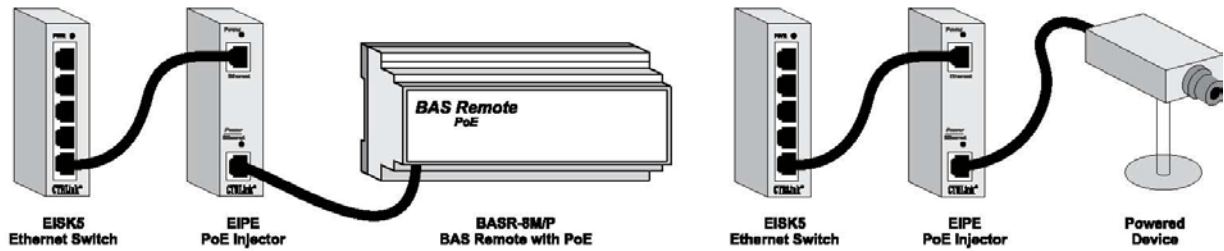

## Ordering Information

Model	Description
CNSEIPE	PoE mid-span power injector

## Contact

### Control Network Solutions Ltd

Studio 7,  
Intec 2,  
Intec Business Park,  
Wade Road,  
BASINGSTOKE,  
Hampshire, RG24 8AG, England

Tel: +44 (0) 1256 818700

Fax: +44 (0) 1256 812520

Email: [cns@control-network-solutions.co.uk](mailto:cns@control-network-solutions.co.uk)

Web: <http://www.control-network-solutions.co.uk>

CTRLink is a registered trademark of Contemporary Control Systems, Inc.

No part of this publication may be reproduced or transmitted in any form or by any means, electronic, mechanical, photocopying, recording, in part or in whole, without prior permission of Control Network Solutions. We reserve the right to make changes without notice to any products herein as part of its continued product development **and** improvements. We do not assume any liability arising out of the application or use of any product or circuit described herein.