

JACE-2

MOUNTING AND WIRING INSTRUCTIONS

This document covers the mounting and wiring of the Vykon[®] JACE-2 series controller. It assumes that you are an engineer, technician, or service person who is performing control system installation. Instructions in this document apply to the following products:



Models	Description
JACE-201	JACE-2 base unit controller, powered by (either ¹):
NPB-PWR	DIN-mountable 24V power module
WPB-XXX	Wall-mount universal AC power adapter, with different models available, where -XXX is either: -US, -EUR, or -UK (vary by AC wall plug).

1. In some markets, an IO-34 accessory module is available, which can power the JACE-2. See [Table 2](#) on page 8 for descriptions of accessory modules. See the *IO-34 Mounting and Wiring Instructions* document for installation details.



Note Not covered in this document is the Niagara^{AX} software installation and configuration required for a fully functioning unit. This includes setting host IP address and password, serial port configuration, and other parameters. Refer to the *JACE NiagaraAX Install and Startup Guide* for this information.

In addition, the mounting and wiring of JACE-2 expansion options are covered in separate documents. See sections [“About Expansion Options,”](#) page 7, and [“Related Documentation,”](#) page 14.

These are the main topics included in this document:

- [Preparation](#), page 2
- [Precautions](#), page 3
- [Mounting](#), page 4
- [Board Layout](#), page 6
- [About Expansion Options](#), page 7
- [Wiring Details](#), page 9
- [Power Up and Initial Checkout](#), page 12

Also included in this document are several appendixes, as follows:

- [Using Status LEDs](#), page 15
- [Maintaining the JACE-2](#), page 16
- [Replacement Parts](#), page 17
- [Certifications](#), page 20
- [Declaration of Conformity](#), page 21

Information and specifications published here are current as of the date of publication of this document. Tridium, Inc. reserves the right to change or modify specifications without prior notice. The latest product specifications can be found by contacting our corporate headquarters, Richmond, Virginia. Products or features contained herein may be covered by one or more U.S. or foreign patents. © 2006 Tridium, Inc.

Preparation

Unpack the JACE-2 and power module (either NPB-PWR or WPM-XXX) and inspect the contents of the packages for damaged or missing components. If damaged, notify the appropriate carrier at once and return any damaged components for immediate repair or replacement. See [“Returning a Defective Unit”](#) on page 19.

- [Included in this Package](#)
- [Material and Tools Required](#)

Included in this Package

Included in this package you should find the following items:

- a JACE-2 base controller.
- These *JACE-2 Mounting and Wiring Instructions*, Part Number 10555, Rev. 1.1
- a hardware bag containing the following items:
 - A grounding wire, with quick-disconnect 0.187” female connector.
- a power module (if ordered), which is required for operation.

The power module can be one of the following:

- [NPB-PWR](#): 24Vac in-line, DIN-mount capable, with grounding wire, *or*
- [WPM-XXX](#): External wall-mount power adapter (input: 90–254Vac, 50–60 Hz, output: 15Vdc, 1A) where *XXX* varies by the AC wall plug (for installation locale):
 - WPM-US (U.S. or Japan installations)
 - WPM-EUR (European installations, type “C” plug)
 - WPM-UK (United Kingdom installations, type “B” plug)

Material and Tools Required

The following supplies and tools may be required for installation:

- DIN rail, type NS35/7.5 (35mm x 7.5mm) and DIN rail end-clips (stop clips), recommended for any installation that includes [NPB-PWR](#) module and/or optional I/O modules.





Note Length of DIN rail is determined by the number of optional DIN-mounted options. See [Figure 1](#) on page 5 for more details.

- If using an NPB-PWR power module, either one of the following:
 - UL listed, Class 2, 24Vac transformer, rated at minimum of 8.5VA to 20VA (approximate range of JACE-2 alone, to fully-expanded unit with four additional IO-16 modules and other option boards). Note that a *dedicated* transformer is required (cannot also power additional equipment).
 - 24Vdc power supply, capable of supplying at least 1A (24W).
- Suitable screws and screwdriver for mounting DIN rail, or if DIN rail not used, for mounting bases of JACE-2 controller, NPB-PWR module (if used), and any I/O modules (if used).
- #2 phillips screwdriver: used to install and remove optional communications modules.
- Small flat-blade screwdriver: used for mounting or removing the JACE-2 from DIN rail, also for making wiring connections to RS-485 connector, and optionally LON and I/O connectors.

Precautions

This document uses the following warning and caution conventions:

 **Caution** Cautions remind the reader to be careful. They alert readers to situations where there is a chance that the reader might perform an action that cannot be undone, might receive unexpected results, or might lose data. Cautions contain an explanation of why the action is potentially problematic.

 **Warning** Warnings alert the reader to proceed with extreme care. They alert readers to situations where there is a chance that the reader might do something that can result in personal injury or equipment damage. Warnings contain an explanation of why the action is potentially dangerous.

Safety Precautions

The following items are warnings of a general nature relating to the installation and start-up of the JACE-2 controller. Be sure to heed these warnings to prevent personal injury or equipment damage.

 **Warning**

- Depending on power module used, the circuit powering the JACE-2 is 24Vac at 50/60 Hz or 24Vdc (if using NPB-PWR), or from 100–240Vac at 50/60 Hz (if using WPM-XXX). Disconnect power before installation or servicing to prevent electrical shock or equipment damage.
- Make all connections in accordance with national and local electrical codes. Use copper conductors only.
- To reduce the risk of fire or electrical shock, install in a controlled environment relatively free of contaminants.
- This device is only intended for use as a monitoring and control device. To prevent data loss or equipment damage, do not use it for any other purpose.

Static Discharge Precautions

Static charges produce voltages high enough to damage electronic components. The microprocessors and associated circuitry within a JACE-2 controller are sensitive to static discharge. Follow these precautions when installing, servicing, or operating the system:

 **Caution**

- Work in a static-free area.
- Discharge any static electricity you may have accumulated. Discharge static electricity by touching a known, securely grounded object.
- Do not handle the printed circuit board (PCB) without proper protection against static discharge. Use a wrist strap when handling PCBs. The wrist strap clamp must be secured to earth ground.

Mounting

Mount the JACE-2 controller in a location that allows clearance for wiring, servicing, and module removal. Additional mounting information applies, as follows:

- [Environmental Requirements](#)
- [Physical Mounting](#)

Environmental Requirements

Note the following requirements for the JACE-2 mounting location:

- This product is intended for indoor use only. Do not expose the unit to ambient conditions outside of the range of 0°C (32° F) to 50°C (122° F) and relative humidity outside the range 5% to 95% non-condensing (pollution degree 1).
- If mounting inside an enclosure, that enclosure should be designed to keep the unit within its required operating range considering a 20-watt dissipation by the controller. This is especially important if the controller is mounted inside an enclosure with other heat producing equipment.
- Do not mount the unit:
 - in an area where excessive moisture, corrosive fumes, or explosive vapors are present.
 - where vibration or shock is likely to occur.
 - in a location subject to electrical noise. This includes the proximity of large electrical contractors, electrical machinery, welding equipment, and spark igniters.

Physical Mounting

The following information applies about physically mounting the unit.

- You can mount the JACE-2 in any orientation. It is not necessary to remove the cover before mounting.
- Mounting on a 35mm wide DIN rail is recommended. The JACE-2 unit base has a molded DIN rail slot and locking clip, as does the 24Vac power module ([NPB-PWR](#)) and both types of I/O expansion modules. Mounting on a DIN rail ensures accurate alignment of connectors between all modules.
- If DIN rail mounting is impractical, you can use screws in mounting tabs on the JACE-2, then in any end-connected accessory ([NPB-PWR](#), etc.). Tab dimensions are on the [last page](#) of this document.

The following procedure provides step-by-step DIN rail mounting instructions for the JACE-2.



Note Mount the JACE-2 prior to mounting any accessory items (24V power module, I/O modules).

Procedure 1 To mount on DIN rail

- Step 1** Securely install the DIN rail using at least two screws, near both ends of the rail.
- Step 2** Position the JACE-2 on the rail, tilting to hook DIN rail tabs over one edge of the DIN rail ([Figure 1](#)).
- Step 3** Use a screwdriver to pry down the plastic locking clip, and push down and in on the JACE-2, to force the locking clip to snap over the other edge of the DIN rail.
- Step 4** Mount any accessory item ([NPB-PWR](#), I/O module) onto the DIN rail in the same manner.
- Step 5** Slide the accessory along the DIN rail to connect its 20-position plug into the JACE-2.

- Step 6** Repeat this for all accessories, until all are mounted on the DIN rail and firmly connected to each other.
- Step 7** To keep the final assembly together, secure at both ends with DIN rail end-clips provided by the DIN rail vendor. This also prevents the assembly from sliding on the DIN rail. See [Figure 1](#).

Figure 1 JACE-2 and accessory mounting details.

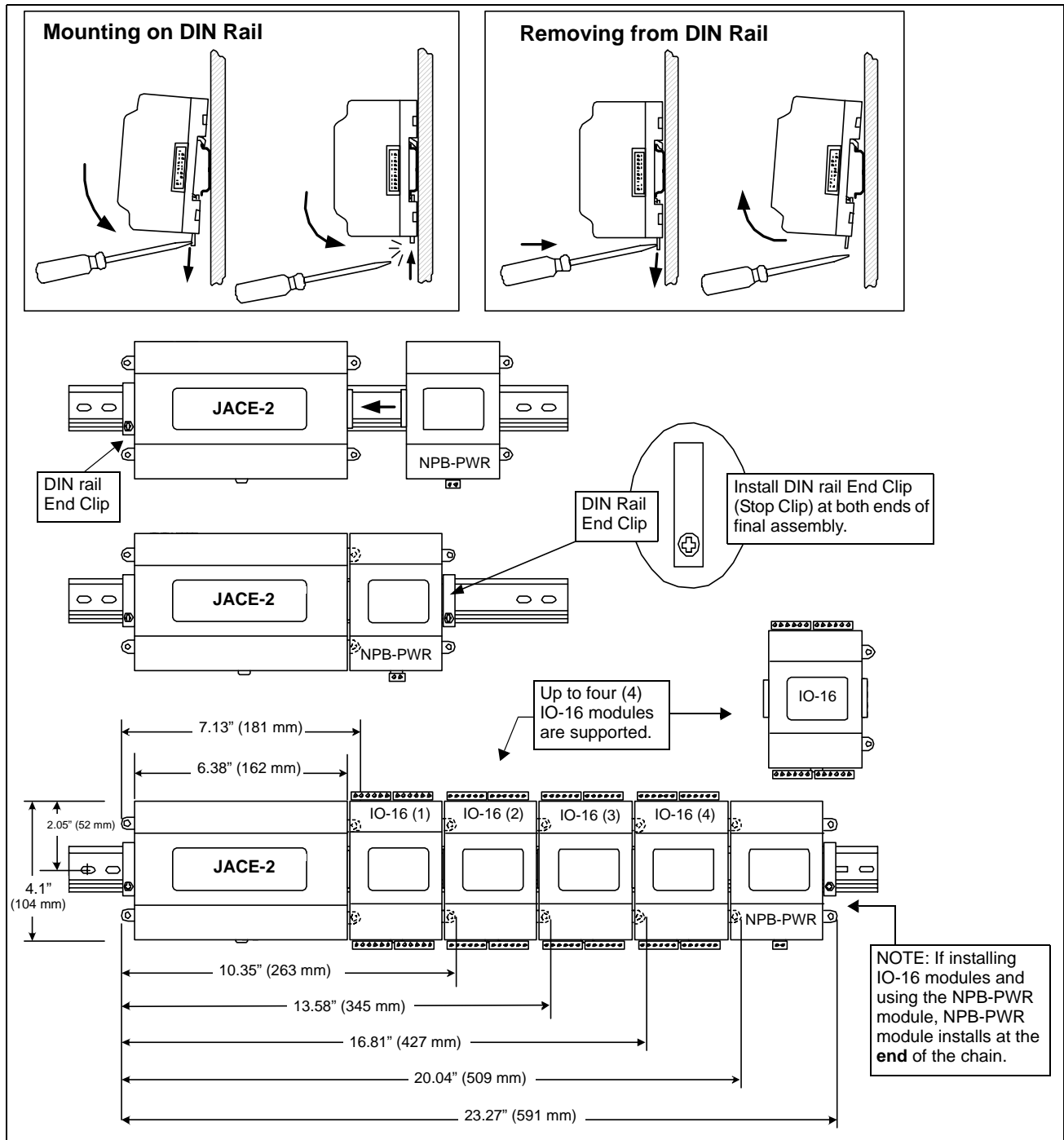

Removing and Replacing the Cover

You must remove the JACE-2 cover to connect the battery (new unit) or to replace the battery, and to install any option boards. The cover snaps onto the base with four plastic tabs (two on each end).

To remove the cover, press in the four tabs on both ends of the unit, and lift the cover off.



Note If accessory modules are plugged into the JACE-2, you may need to slide them away from the unit to get to the cover tabs.

To replace the cover, orient it so the cutout area for comm ports is correct, then push inwards to snap in place.

Board Layout

Figure 2 shows the location of LEDs, option slots, and other features of the JACE-2 with cover removed. For a side view of communications ports and other features, see Figure 4 on page 11.

Figure 2 JACE-2 board layout details.

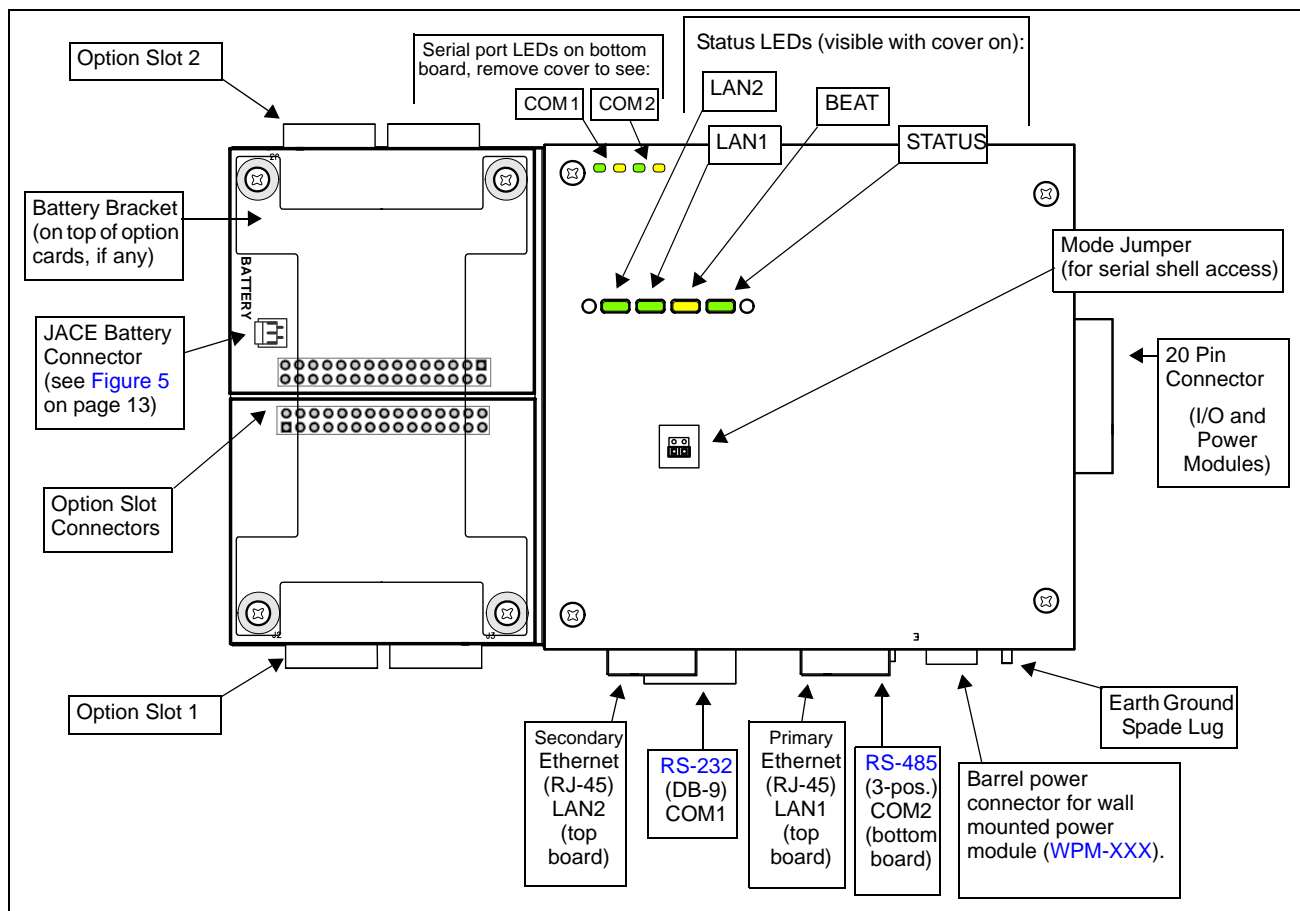

About Expansion Options

The JACE-2 provides for *field-installable* expansion with two kinds of options:

- **Option cards**—Install on connectors inside the JACE-2 base unit. See “[About Option Cards](#)”.
- **Accessory modules**—To “chain” onto the JACE-2’s 20-pin connector. See “[About Accessory Modules](#)”.

About Option Cards

The JACE-2 has two (2) option slots for custom option cards designed for use with the JACE-2. Each slot has a 30-pin connector on the JACE-2 base board. See [Figure 2](#) on page 6.



Warning Power to the JACE-2 must be OFF when installing or removing option cards, or damage will occur! Also, you must be very careful to plug an option card into its connector properly (pins aligned).

Option cards typically provide additional communications features, such as the following available models (with others still in development) listed in [Table 1](#).

Table 1 JACE-2 option cards.

Model	Description	Notes
NPB-LON	FTT-10A LON (LonWorks) adapter with a 2-position removable screw-terminal connector plug.	Up to 2 LON option cards may be installed. <ul style="list-style-type: none"> • If one LON option, it operates as LON1, regardless of slot. • If two LON options, LON1 is Option slot 1, LON2 is Option slot 2.
NPB-2X-485	Dual, optically-isolated, RS-485 adapter with two 3-position removable screw-terminal connector plugs.	One or two 485 option cards may be installed, with COM assignments as: <ul style="list-style-type: none"> • If one 485 option (regardless of slot), ports are COM3 and COM4. • If two 485 options, ports are COM3 and COM4 for Option Slot 1, and COM5 and COM6 for Option Slot 2.
NPB-MDM	56Kbps Auto-dial/Auto-answer Modem with one RJ-11 connector for phone line.	Maximum of one. Does not have own UART (unlike NPB-2X-485). Must be installed in Option Slot 1, where it operates as COM1. This disables the RS-232 base serial port (DB-9 connector) on the JACE-2 during normal operation. Note: If an NPB-MDM is installed, and the “mode jumper” (see Figure 2) is put in “Serial Shell” position, the JACE-2 base RS-232 port becomes active immediately following a reboot. This allows an RS-232 connection to the “serial shell” for debugging purposes. To re-enable the modem, you must put the mode jumper back in the “Normal” position, and reboot again.

Mounting Option Cards

For complete details, see the mounting & wiring instructions document that accompany the specific option card. The following procedure provides a basic set of steps.

Procedure 2 Mounting option cards on a JACE-2.

- Step 1** Remove power from the JACE-2—see the previous [Warning](#).
- Step 2** Remove the cover. See “[Removing and Replacing the Cover](#),” page 6.
- Step 3** Remove the battery and bracket assembly by taking out the four screws holding it in place, setting the screws aside for later. Unplug the battery from the connector on the JACE-2.

- Step 4** Remove the blanking end plate for the slot you are installing the option card into. (Retain the blanking plate in case the option card must be removed at a later date.)
- Step 5** Carefully insert the pins of the option card into the socket of the appropriate option card slot. The mounting holes on the option board should line up with the standoffs on the base board. If they do not, the connector is not properly aligned. Press until the option card is completely seated.
- Step 6** Place the custom end plate that came with the option card over the connector(s) of the option card.
- Step 7** Plug the battery connector plug into the battery connector on the JACE-2.
- Step 8** Set the battery and bracket assembly back over the option card slots, with the mounting holes aligned with the standoffs.
- Step 9** Place the four screws through the battery bracket, end plates, and into the standoffs on the JACE-2 base board. Hand tighten these screws.
- Step 10** Replace the cover.

About Accessory Modules

The JACE-2 has a 20-pin, right-angle, Euro-DIN connector that accepts custom-built accessory modules. The connector provides power and signal lines to any connected modules, and is located on the end of the JACE-2 opposite to the option cards.



Note Unlike with option cards (which become *damaged* if plugged/unplugged from a JACE-2 while it is powered ON), DIN-rail type accessory modules can be plugged into, or removed from, a powered JACE-2. However, this is not recommended, because I/O points are detected only at boot time. Therefore, a shutdown cycle is needed anyway when changing installed accessory modules.

Each accessory module has a DIN-mount base, and provides two (2) 20-pin connectors that allow you to “chain” multiple accessories (see [Procedure 1](#) on page 4). [Table 2](#) lists the currently available accessory modules.

Table 2 JACE-2 accessory modules.

Model	Description	Notes
NPB-PWR	DIN-mountable, 24V isolated power module, used to power JACE-2 from a dedicated, external, Class-2, 24Vac transformer or a 24Vdc power supply.	<ul style="list-style-type: none"> Wiring is covered in <i>this document</i>, see “NPB-PWR,” page 10. Only one NPB-PWR per JACE-2. Do not install if using WPM-XXX.
IO-16	DIN-mountable, 16 points I/O module, used to provide I/O points as noted.	Provides the following I/O points: <ul style="list-style-type: none"> 8 - Universal Inputs (UIs). 4 - Digital Outputs (DOs), SPST-relay type. 4 - Analog Outputs, 0–10Vdc type. Up to four (maximum) IO-16 accessory modules are supported.
IO-34 (available only in some markets)	DIN-mountable, combined 34 points I/O with 24V isolated power module, used to provide I/O points as well as power JACE-2 from a dedicated, external, Class-2, 24Vac transformer or a 24Vdc power supply.	Only one IO-34 per JACE-2. Provides the following I/O points: <ul style="list-style-type: none"> 16 - Universal Inputs (UIs). 10 - Digital Outputs (DOs), SPST-relay type. 8 - Analog Outputs, 0–10Vdc type. Up to 2 additional IO-16 modules can be used. Do not power the IO-34 if using WPM-XXX .

Wiring Details

See [Figure 2](#) on page 6 to locate connectors and other components on the JACE-2 controller.

Make connections to the JACE in the following order.

1. Install any option boards (LON, RS-485, or modem) in option slots 1 and 2. See [“Mounting Option Cards,”](#) page 7 for a general procedure. For complete details, refer to the specific mounting and wiring guide that shipped with the option board.
2. Connect supplied earth grounding wires (with spade connector) from the earth ground lug on the JACE-2 and any accessory modules (if used) to a nearby earth grounding point. See [“Grounding”](#) for details.
3. Prepare power wiring (leave the unit powered off). See [“Power Wiring”](#) for details.
4. Connect communications cables. See [“Communications Wiring,”](#) page 11 for ports available on the JACE-2 base unit. For ports on any installed option board (LON, RS-485, modem) see the specific mounting and wiring guide for any additional details.
5. If IO accessory modules are installed, connect the I/O wiring. Refer to the appropriate mounting and wiring guide for complete details.
6. Connect the backup battery to the JACE-2 battery connector, and apply power to the unit. See [“Power Up and Initial Checkout,”](#) page 12.

Grounding

An earth ground spade lug (0.187") is provided on the base of the JACE-2 for connection to earth ground. For maximum protection from electrostatic discharge or other forms of EMI, connect the supplied earth grounding wire to this lug and a nearby earth ground (see [Figure 3](#) on page 10). Keep this wire as short as possible.

Power is provided for JACE-2 plug-in accessory modules through the 20-pin accessory connectors. However, you should also connect the earth ground spade lug of *each accessory module* to ground in the same manner.

Power Wiring

The JACE-2 must be powered by an approved 15 Vdc power source. This can be *either*¹ an external wall mount AC adapter (WPM-XXX) or the DIN-mount 24Vac-powered module (NPB-PWR). The JACE-2 controller does not include an on/off switch. To apply power, plug in the power connector to either the JACE-2 (if WPM-XXX) or the NPB-PWR.



Caution

Do not connect *both* the WPM-XXX and NPB-PWR supplies at the same time, or equipment damage may result.

If desired, you can use the wall mount WPM-XXX in your office (to initially commission the JACE-2), and then install the JACE-2 at the job using an NPB-PWR module. The following sections provide more details:

- [WPM-XXX](#) (Wall Power Modules)
- [NPB-PWR](#) (24Vac-powered in-line module)

1. In some markets, a third power option is available: an **IO-34** accessory module, which is a combination of the NPB-PWR module and two IO-16 modules (plus two extra relays). Please refer to its mounting and wiring instructions document for more details. For general information on accessory modules, see [“About Accessory Modules,”](#) page 8.

WPM-XXX

All models of wall power modules (US, EUR, UK, JA) are self-contained, isolated, switching power supplies designed to plug into a standard building power receptacle of appropriate voltage. To supply power to the JACE-2, you then simply plug the barrel connector plug from the WPM-XXX into the barrel power connector on the JACE-2 base board (see [Figure 4](#) on page 11).



Caution Do not plug the barrel connector plug from the WPM-XXX into the JACE-2 until all other mounting and wiring is completed. See “[Power Up and Initial Checkout](#),” page 12.

NPB-PWR

Using the NPB-PWR module lets you power the JACE-2 (and if installed, IO-16 modules) from a dedicated Class 2, 24Vac transformer, or from a 24Vdc power supply. If installing IO-16 modules, the NPB-PWR installs as the *last* (end) module in the chain. See [Figure 1](#) on page 5.



Note If powering from a 24V transformer, do *not* power any other equipment with it. Otherwise, conducted noise problems may result. Also, do not ground either side of the transformer’s 24V secondary.

Located at the bottom of the NPB-PWR module is a 2-position power connector, and an earth ground spade lug, as shown in [Figure 3](#).

Figure 3 NPB-PWR module wiring connections.

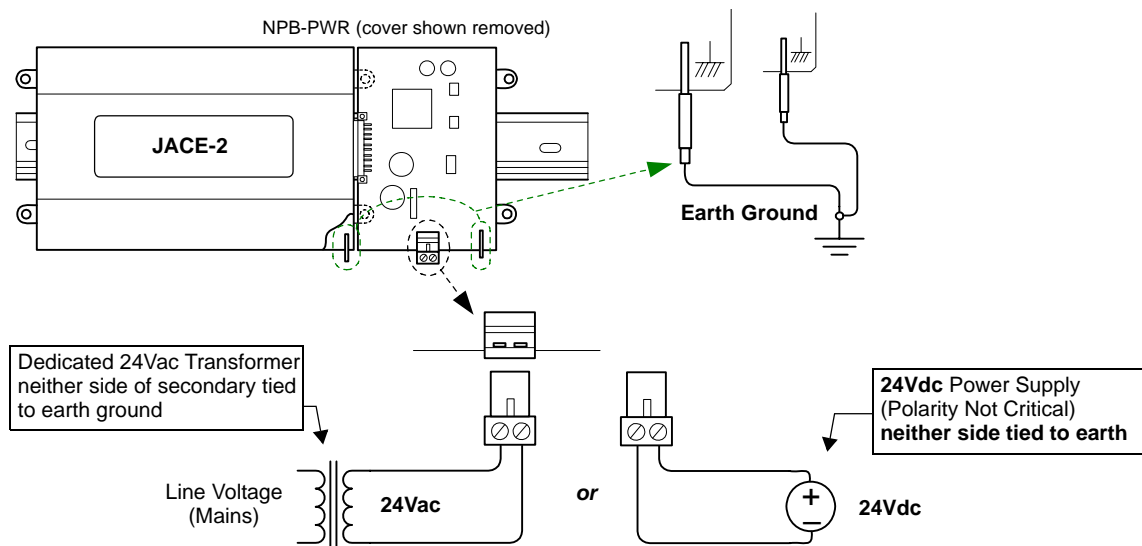

Connect the supplied earth ground wire to a nearby earth ground point. Unplug the power connector plug from the module and make connections to it as shown in [Figure 3](#).



Caution Do not plug 24V power into the NPB-PWR (reinsert connector plug) until all other mounting and wiring is completed. See “[Power Up and Initial Checkout](#),” page 12.

Power consumption depends on installed accessories and option boards, and may vary from:

- JACE-2 with NPB-PWR module alone: approximately 8.5 VA (AC) or 8.5 W (DC)
- JACE-2 with NPB-PWR and four (4) IO-16 modules, plus option boards: up to 20 VA (AC) or 20 W (DC)

Communications Wiring

Connect communications wiring to the JACE-2 using ports on the bottom of the unit (Figure 4), which include:

- Ethernet
- Serial



Note Prior to connecting cables, provide strain relief for them to prevent damage to the controller.

Figure 4 JACE-2 bottom side (cover removed).

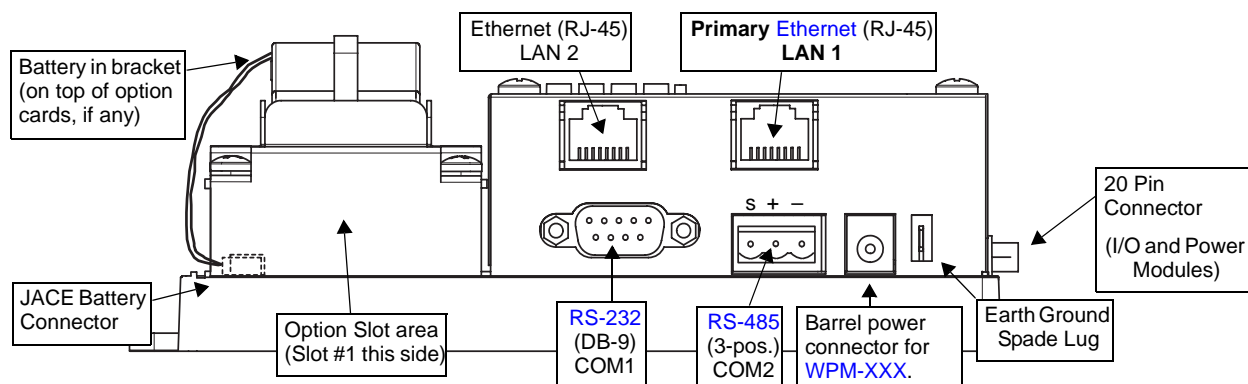

Ethernet

Two, female 10/100-Mbit Ethernet connections are provided on the JACE-2. These are RJ-45 connectors labeled LAN2 and LAN1. Use a standard Ethernet patch cable for connecting to a hub or Ethernet switch. An activity LED for each Ethernet port is visible, and are labeled “LAN2” and “LAN1” on the cover.

The factory-default IP address for **LAN1** on a JACE-2 is **192.168.1.12n**, where the last numeral **n** in the address matches the JACE-2’s serial number, and subnet address is **255.255.255.0**. By default, LAN2 on a JACE-2 is disabled. Refer to the *JACE NiagaraAX Install and Startup Guide* for details on changing IP address.



Note Typically, you *only use LAN1* (primary port), unless you have a specific application for isolating a driver’s network traffic to a separate LAN, using LAN2. Do *not* use LAN2 as the primary port.

Serial

There are two serial ports on the JACE-2 base unit. Each has a UART capable of operation up to 115,200 baud. At the bottom of the board (see Figure 4), the left port is an **RS-232** port using an DB-9 plug (male) connector. To the right of this is a two-wire with shield, isolated **RS-485** port, using a screw-terminal connector plug.



Note A green “receive” LED and yellow “transmit” LED are provided for each serial port. These LEDs are located on the bottom board, on the *opposite side* of the serial connectors (see Figure 2 on page 6). These LEDs are labeled on the board (COM1, COM2) and are not visible with the cover on.

Connect the Backup Battery

RS-232—An RS-232 serial port using a male DB-9 connector always operates as COM1. You can use standard DB-9 serial cables with this port. The JACE-2 is a serial DTE device, such another DTE device (PC, for example) requires a “null modem” cable. If connecting the JACE-2 to a DCE device (modem, for example), a straight-through cable is used. [Table 3](#) provides standard serial DB-9 pinouts.



Note If a modem option card (NPB-MDM) is installed, this port becomes disabled—except if rebooted with the mode jumper (see [Figure 2](#) on page 6) in the “Serial Shell” position.

Table 3 Serial port (RS-232 and RS-485) pinouts.

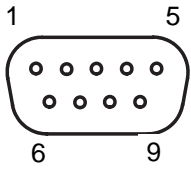
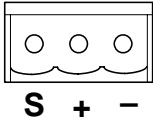
Base RS-232 DB-9 Port (COM1)			Base RS-485 Port (COM2)
Pinout References	Signal	DB-9 Plug Pin	Pinouts
DB-9 Plug (male) 	DCD	Data carrier detect	3-position connector (male) 
	RXD	Receive data	
	TXD	Transmit data	
	DTR	Data terminal ready	
	GND	Ground	
	DSR	Data set ready	
	RTS	Request to send	
	CTS	Clear to send	
		not used on the JACE-2	

RS-485—An RS-485, optically isolated port uses a 3-position, screw terminal connector and always operates as COM2. Wire to this connector with shielded 18-22AWG wiring (refer to the TIA/EIA-485 standard). As shown in [Table 3](#), the screw terminals (from left-to-right) are shield, plus (+), and minus (–).

Power Up and Initial Checkout

Ensure power wiring to the JACE-2 is ready—see the “[Power Wiring](#)” section on page 9. Refer to [Figure 2](#) on page 6 for the locations of the JACE-2 battery connector, status LEDs and barrel power connector (for WPM-XXX only). Refer to [Figure 3](#) on page 10 for location of the power connector on the [NPB-PWR](#) module.

Following all mounting and wiring, perform the following:

Procedure 3 Initial power up and checkout

- Step 1** [Connect the Backup Battery.](#)
- Step 2** [Apply Power.](#)
- Step 3** [Check the Status LEDs.](#)

Connect the Backup Battery

With the cover removed from the JACE-2 (see “[Removing and Replacing the Cover,](#)” page 6), locate the red and black wires coming from the backup battery, with 2-position connector plug. Insert the plug into the battery connector on the bottom board (below option slot 2 area), as shown in [Figure 5](#).

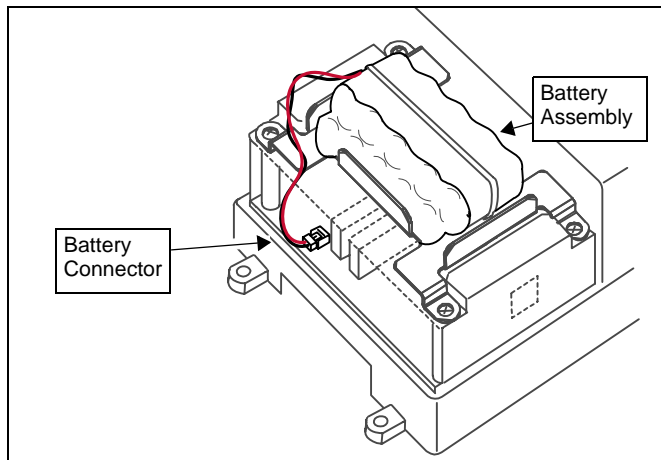
Figure 5 Backup battery connector on JACE-2 bottom board.

The connector is keyed—you cannot insert it incorrectly. The red (positive) connection should be the furthest from the two 30-pin option board connectors. For more battery details, see [“About the Battery,”](#) page 13.

Apply Power

Apply power to the JACE-2 by plugging in the power plug into either the JACE-2 (if wall mount AC adapter [WPM-XXX](#)) or the 24V-powered [NPB-PWR](#) module.



Caution Do not connect *both* the WPM-XXX and NPB-PWR supplies at the same time, or equipment damage may result, or a power outage may go unrecognized.

Check the Status LEDs

When power is applied, the green LED labeled “STATUS” will light. This indicates that the system is OK and that power is applied. Once the JACE-2 boots, the yellow “BEAT” (heartbeat) LED will begin blinking, with a typical rate of about 1 Hz. Blinking should begin within 30 seconds after power is applied.

If after applying power, the STATUS LED goes out, or if the BEAT LED comes on (steady) and stays lit longer than two minutes, contact Systems Engineering for technical assistance. See also the [“Using Status LEDs”](#) section on page 15.

About the Battery

The JACE-2 is provided with a custom 10-cell NiMH battery pack mounted to the unit (under the cover). This battery allows the JACE to continue operation through very short power bumps (a few seconds in duration). If a longer power outage occurs, the battery provides enough run time for the JACE-2 to backup data and then shutdown. Typically, this is one minute. Shutdown occurs automatically, after data is backed up to on-board flash memory.

The JACE-2 charges the battery during normal operation, until fully charged. Typically, the charge operation completes within 18 hours. Following a power outage, the battery is charged again, as necessary. The power and battery circuitry is monitored by a station running on the JACE (via the PowerMonitorService). Station alarms are generated whenever primary power is lost, or if the battery is uncharged or unable to hold a sufficient charge.

The battery should be replaced approximately every three years, or more often if the unit is in a high temperature environment.



Note A NiMH battery characteristic is to lose charge if not left in charge mode (trickle charge). Leaving the battery unconnected, or in the unit powered off will cause the battery to fully discharge in a matter of weeks. Note that in the case of a new JACE-2, it ships from the factory with a completely discharged battery. Therefore, allow at least 18 hours for the battery to charge if it has not been in a powered unit.

For more information on the use and replacement of the battery, refer to the [“Required Battery Maintenance”](#) section on page 16.

Related Documentation

For more information on configuring and using the JACE-2 controller, consult the following documents:

- *JACE NiagaraAX Install and Startup Guide*
- *IO-16 Installation and Configuration Instructions*
- *IO-34 Installation and Configuration Instructions*
- *NPB-LON Option Installation Sheet*
- *NPB-2X-485 Option Installation Sheet*
- *NPB-MDM Option Installation Sheet*
- *NiagaraAX Ndio Guide*
- *NiagaraAX User Guide*

Using Status LEDs

The JACE-2 controller includes several LEDs that can help determine the status of the unit. They are located in two places: the top of the controller (visible through the cover), and for serial ports, on the bottom board (only with cover removed). From left-to-right these LEDs include:

- [Ethernet Ports](#)
- [Heartbeat](#)
- [Status](#)
- [Serial Ports](#)

Refer to [Figure 2](#) on page 6 for the exact locations of status LEDs on the JACE-2 controller.

Ethernet Ports

Each Ethernet port (“LAN2”, “LAN1”) has one green LED, visible on the top cover.

A “LANx” LED indicates activity on that port as follows:

- **Off**—No Ethernet link is made
- **On**—Ethernet link is present, but no activity on the LAN
- **Blinking**—Ethernet link is present with data activity on the LAN.

Heartbeat

The “BEAT” LED is located to the right of the Ethernet status LEDs, and is yellow. Under normal operation, this LED should blink about once per second. If the heartbeat LED stays *on constantly*, *does not light*, or blinks *very fast* (more than once per second), contact System Engineering for technical support.

Status

The “STATUS” LED is located to the right of the heartbeat (“BEAT”) LED, and is green. This LED provides a CPU machine status check, and should remain lit whenever the JACE-2 is powered. If the STATUS LED *does not light* while power is applied, contact System Engineering for technical support.

Serial Ports

LEDs for the two serial ports are located on the JACE-2’s *bottom* board, on the *opposite side* of the RS-232 and RS-485 ports (see [Figure 2](#) on page 6). Labels “COM1” and “COM2” correspond to the software configuration of the COM ports. LEDs show the transmit and receive activity for the serial ports and optional modem.



Note You must remove the cover to the serial port LEDs. See [“Removing and Replacing the Cover,”](#) page 6.

- The **yellow** transmit LED indicates that the JACE-2 is *sending* data out the serial port over a communications line to a connected device.
- The **green** receive LED indicates that the JACE-2 is *receiving* data from a connected device.

These LEDs provide a fixed on-time when data is detected on the port. If these LEDs are on constantly, this indicates a problem with the communications channel, such as a shorted wire or reversed wiring.

Maintaining the JACE-2

This section provides information on the following topics:

- [Cleaning](#)
- [Required Battery Maintenance](#)
- [Replacement Parts](#)
- [Replacing the JACE-2 base assembly](#)
- [Returning a Defective Unit](#)

Cleaning

If dust or metal filings are present inside the unit, clean with vacuum or compressed air. Otherwise, no cleaning inside the unit is required. Optionally, if the cover becomes dirty, you can wipe it with a damp cloth and mild detergent.

Required Battery Maintenance

Battery life expectancy is a function of its discharge cycles (the number of discharges and their depth) and the ambient temperature of the battery during normal operation. In most applications, the battery should see relatively few discharges. Therefore, ambient temperature has more to do with determining the life expectancy of the battery than does any other factor. If the JACE-2 is installed in a conditioned space, the battery should provide dependable service for approximately three years (average). In an environment where the operating temperature is higher (that is, 50°C or 122°F), you should only expect the battery to last approximately one year.

The NiMH battery in the JACE-2 controller is fully discharged when factory shipped. Additionally, NiMH batteries lose charge over time if not kept trickle-charged (for more details, see [“About the Battery,”](#) page 13). Therefore, even a new unit (or replacement battery) will require up to 18 hours of powered operation before it can provide reliable backup power (is at full charge).

The JACE-2 monitors the battery and periodically loads the battery to test its ability to maintain battery-backed functions. Investigate any battery trouble message, and check the battery connections to the unit. Replace the battery as required. To order a new battery, see the [“Standard Replacement Parts”](#) section on page 17.

Replacing the Battery

A replacement battery is a complete assembly, that is a battery pack pre-attached to a battery bracket. See [Figure 5](#) on page 13.



Caution Use only battery packs approved for use with the JACE-2.

To replace the battery, proceed as follows:

Procedure 4 Mounting option cards on a JACE-2.

-
- Step 1** Remove power from the JACE-2.
- Step 2** Remove the cover. See [“Removing and Replacing the Cover,”](#) page 6.
- Step 3** Remove the old battery and bracket assembly by taking out the four screws holding it in place, setting the screws aside for later. Unplug the battery from the connector on the JACE-2.

- Step 4** Plug the battery connector plug of the *replacement battery* into the battery connector on the JACE-2.
- Step 5** Set the replacement battery/bracket assembly back over the option card slots, with the mounting holes aligned with the standoffs.
- Step 6** Place the four screws through the battery bracket, option cards blanking plates, and into the standoffs on the JACE-2 base board. Hand tighten these screws.
- Step 7** Replace the cover.
- Step 8** Restore power to the JACE-2 and verify normal operation.

Replacement Parts

Servicing the JACE-2 may call for replacement parts. There are three categories of parts:

- [Non-replaceable Parts](#)
- [Standard Replacement Parts](#)
- [New Replacement Units](#)

Non-replaceable Parts

Other than the parts listed in the replacement parts sections, there are no serviceable components on the base assembly.

Memory

Any addition, modification, or replacement of memory components requires software configuration and is not a field upgrade. For additional information on modifying the memory capacity of the JACE-2, consult your regional Tridium office.

Fuse

The JACE-2 contains a non-user replaceable fuse, soldered on the circuit board. This fuse provides protection from internal shorts or connection to incorrect power supplies. If the fuse circuitry is suspect, contact your regional Tridium office for technical support. See the “[Returning a Defective Unit](#)” section on page 19.

Standard Replacement Parts

Standard replacement parts are listed in [Table 4](#) and can be ordered from stock without restriction. Standard replacement parts cannot be returned for credit and should be disposed of in an appropriate manner.

Table 4 Standard replacement parts.

Part Number	Description
10499	NiMH Battery Pack (with battery bracket)—see “ Replacing the Battery ,” page 16
10027	RS-485 connector plug, 3-position



Note Screws used for the JACE-2 are standard #6-32 x 3/8" types, which you can obtain locally if lost.

New Replacement Units

To replace a faulty unit, order and install a *new* JACE-2—please note that JACE-2 series products do *not* have special “field replacement units,” or FRUs, with separate part numbers.

If the faulty JACE-2 is *still in warranty*, you can receive credit by returning it to Tridium. Be sure to contact Tridium for a return authorization (RA) number before shipping an item for return credit. See “[Returning a Defective Unit](#),” page 19, for more details.



Note Before ordering a new JACE-2, it is strongly recommended that you contact your normal technical support resource to eliminate the possibility of a software issue or mis-configuration problem.

Replacing the JACE-2 base assembly



Caution Before handling circuit boards, discharge any accumulated static by touching the metal surface of the JACE-2. For details, see the “[Static Discharge Precautions](#)” section on page 3.

To replace the JACE-2 base assembly in the field, proceed as follows:

Procedure 5 Replacing a JACE-2 base assembly.

Step 1 Using the appropriate NiagaraAX software tool, back up the JACE-2’s configuration to your PC.

Step 2 Remove power to the JACE-2. The unit should power down automatically.



Note If IO accessory modules are installed, and any I/O points have voltage, turn the devices off or disconnect power to them.

Step 3 Note positions of all communications and other wiring cables going to the JACE-2, as well as all installed accessory modules (if they must be removed). If necessary, label connectors and accessory modules to avoid mis-connection later, after JACE-2 is replaced.

Step 4 Unplug all Ethernet, serial, LON, modem, and I/O connectors from the JACE-2, and unplug its earth ground wire.

Step 5 If IO accessory modules are installed:

- If DIN rail mounting with DIN end-clips was used, you may be able to remove the DIN rail end clip that secures the JACE-2 end of the assembly, and then *slide* the JACE-2 away from the rest of the assembly. Then you can remove the JACE-2 from the DIN rail (see [Figure 1](#) on page 5), leaving the mounting and wiring of IO modules untouched.

In this case, after removing the JACE-2 from the DIN rail, skip ahead to [Step 6](#).

- If tab (screw) mounting was used *instead* of DIN rail mounting, or if a combination of DIN rail mounting *and* tab screws (into the JACE-2’s “accessory side” tab holes, see [last page](#)), you will need to remove the accessory modules *first*, before removing the JACE-2.

In this case:

- a. Making a careful note of all wiring terminations, unplug the I/O connector plugs and earth ground wires from the installed IO modules.

- b. Remove the installed accessory modules, starting with the end module. Modules may be secured by screws in mounting tabs or clipped to a DIN rail, or fastened by some combination. See [Figure 1](#) on page 5 for details on removal from (and mounting onto) DIN rail.
 - c. Remove any screws fastening the JACE-2, and remove it (see [Figure 1](#)).
- Step 6** Remove the cover from the old JACE-2 (see “[Removing and Replacing the Cover,](#)” page 6). Note the position of installed option boards, if any. You must transfer them to the replacement JACE-2.
- Step 7** Remove the option boards from the old JACE-2 and install them into the replacement JACE-2, if applicable. See “[Mounting Option Cards,](#)” page 7, for more details.
- Step 8** Mount the replacement JACE-2 as it was previously, using the same DIN rail location and/or screws.
- Step 9** Reconnect/remount any removed accessory modules, being careful to replace in the same order, using the same DIN rail location and/or screws. Secure all accessory modules as done previously.
- Step 10** Reconnect the earth ground wires to the JACE-2 grounding lug and any installed accessory modules.
- Step 11** Reconnect any Ethernet, serial, modem, and I/O connectors to the JACE-2 and any installed accessory modules.
- Step 12** If using IO modules, and any of your I/O points have voltage, turn the devices back on, or reconnect power to them.
- Step 13** Restore power to the JACE-2. It should boot up as a new unit (see “[Check the Status LEDs,](#)” page 13).
- Step 14** Using the NiagaraAX platform tools, re-commission the JACE-2, and install the saved station database. For more details, see the *JACE NiagaraAX Install and Startup Guide*.

Returning a Defective Unit



Note If the defective unit is under warranty, please follow return instructions provided in this section. If the unit is *out of warranty*, please discard it.

- Do not return an out-of-warranty JACE-2 to Tridium.
- There is no “return for repair-and-return” service available for any of the JACE-2 series products.

For proper credit on an in-warranty unit, ship the defective unit to Tridium within 30 days.

Prior to returning the unit, contact one of the following Tridium offices to obtain a return authorization (RA) number and other instructions. Please provide:

- Product model
- Serial number
- Nature of the defect

United States

Phone: 804-254-7086, ext. 11

Return to:

Tridium, Inc.
 2256 Dabney Road, Suite C
 Richmond, VA 23230
 Attn: Return Department RA# _____

Europe

Phone: +44 (0) 1403 740290

Fax: +44 (0) 1403 741804

Return to:

Tridium Europe Ltd
1, The Grainstore
Brooks Green Road
Coolham
West Sussex
RH13 8GR
United Kingdom
Attn: Return Department RA# _____

Email for technical support:

supportuk@tridium.com

Email for product orders:

ordersuk@tridium.com

Asia/Pacific

Phone: +65 6887 5154

Fax: +65 6887 5342

Mobile: +65 9665 6024

Address:

Tridium Asia Pacific Pte Ltd
101 Cecil Street,
#10-11, Tong Eng Building,
Singapore 069533

Attn: Mr Lim Hoon Chiat, Engineering Manager RA# _____

Email for technical support:

hclim@tridium.com

Sales: (Australia): **Phone:** +61 7 5539 1211 **Fax:** +61 7 5597 2334

(Japan): **Phone:** +81 044 829 1750

Certifications

Federal Communications Commission (FCC)

This equipment generates, uses, and can radiate radio frequency energy, and if not installed and used in accordance with the instruction manual, may cause interference with radio communications. It has been tested and found to comply with the limits for a Class A computing device pursuant to Subpart J of Part 15 of FCC Rules, which are designed to provide reasonable protection against such interference when operated in a commercial environment. Operation of this equipment in a residential area may cause interference, in which case, users at their own expense will be required to take whatever measures may be required to correct the interference. Any unauthorized modification of this equipment may result in the revocation of the owner's authority to continue its operation.

Canadian Department of Communications (DOC)



Note This Class A digital apparatus meets all requirements of the Canadian Interference-Causing Equipment Regulations.



Note Cet appareil numérique de la classe A respecte toutes les exigences du Règlement sur le matériel brouilleur du Canada.

Declaration of Conformity

JACE-2

Application of Council Directive: 89/336/EEC, 92/31/EEC, 73/23/EEC, 93/68/EEC

Manufacturer's Name: Tridium, Inc.

Manufacturer's Address: 3951 Westerre Parkway, Suite 350
Richmond, Virginia 23233
United States of America

Manufacturer's Representative: Terry Casey, President
Tridium Europe Ltd
1, The Grainstore
Brooks Green Road
Coolham, West Sussex, RH13 8GR
United Kingdom

Product Model Number: JACE-201, with the following: IO-34, IO-16, NPB-PWR, NPB-LON, NPB-MDM

Type of Equipment: Information Technology Equipment

EMC Standards Applied:	Standard	Description		Criteria Met
	EN 61000-6-4	Electro-Magnetic Compatibility Emissions	Generic	Complies
	EN 61000-6-2 and EN 61000-6-1, as defined below	Electro-Magnetic Compatibility	Immunity	Complies, as documented below
	EN50081-2	Generic Emission Standard for residential, commercial, and light industrial environment		
	CISPR 11	Limits of Radio Disturbance - Radiated Emissions Limits of Radio Disturbance - Conducted Emissions		PASS Class A PASS Class A
	IEC 61000-4-2	E.S.D		PASS Criteria A
	IEC 61000-4-3	Radiated Field Immunity		PASS Criteria A
	IEC 61000-4-4	Electrical Fast Transient Immunity (Signal Ports) Fast Transient Immunity (AC Power)	Electrical	PASS Criteria A PASS Criteria A
	IEC 61000-4-5	Surge Immunity		PASS Criteria A
	IEC 61000-4-6	Conducted Immunity		PASS Criteria A
	EN 61000-3-2	Harmonic Current		PASS
	EN 61000-3-3	Quasi-Stationary Harmonics Test, Voltage Fluctuation and Flicker		PASS
	IEC 61000-4-11	Voltage Dips Voltage Interrupts		PASS Criteria A PASS Criteria A
	IEC 61010-10-1: 90 +A1:92 + A2:95	Safety requirement for electrical equipment for measurement, control and laboratory use		PASS

I, **Terry Casey**, hereby declare that the equipment specified above conforms to the above Directives and Standards.

Place: Coolham, West Sussex, United Kingdom

September 1, 2005

Position: President, Tridium Europe Ltd.

Tab Mounting Dimensions

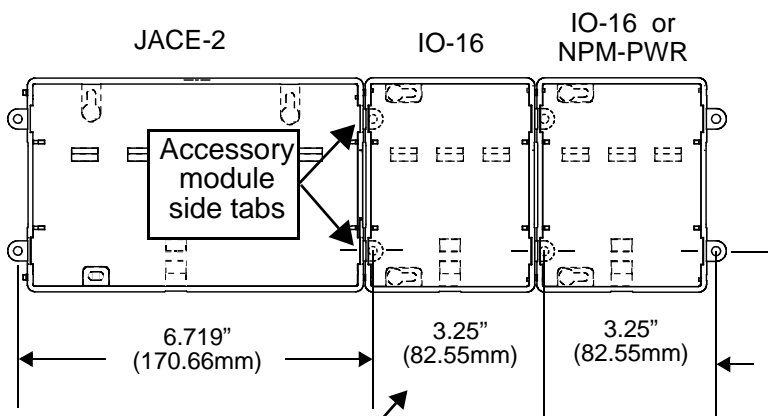
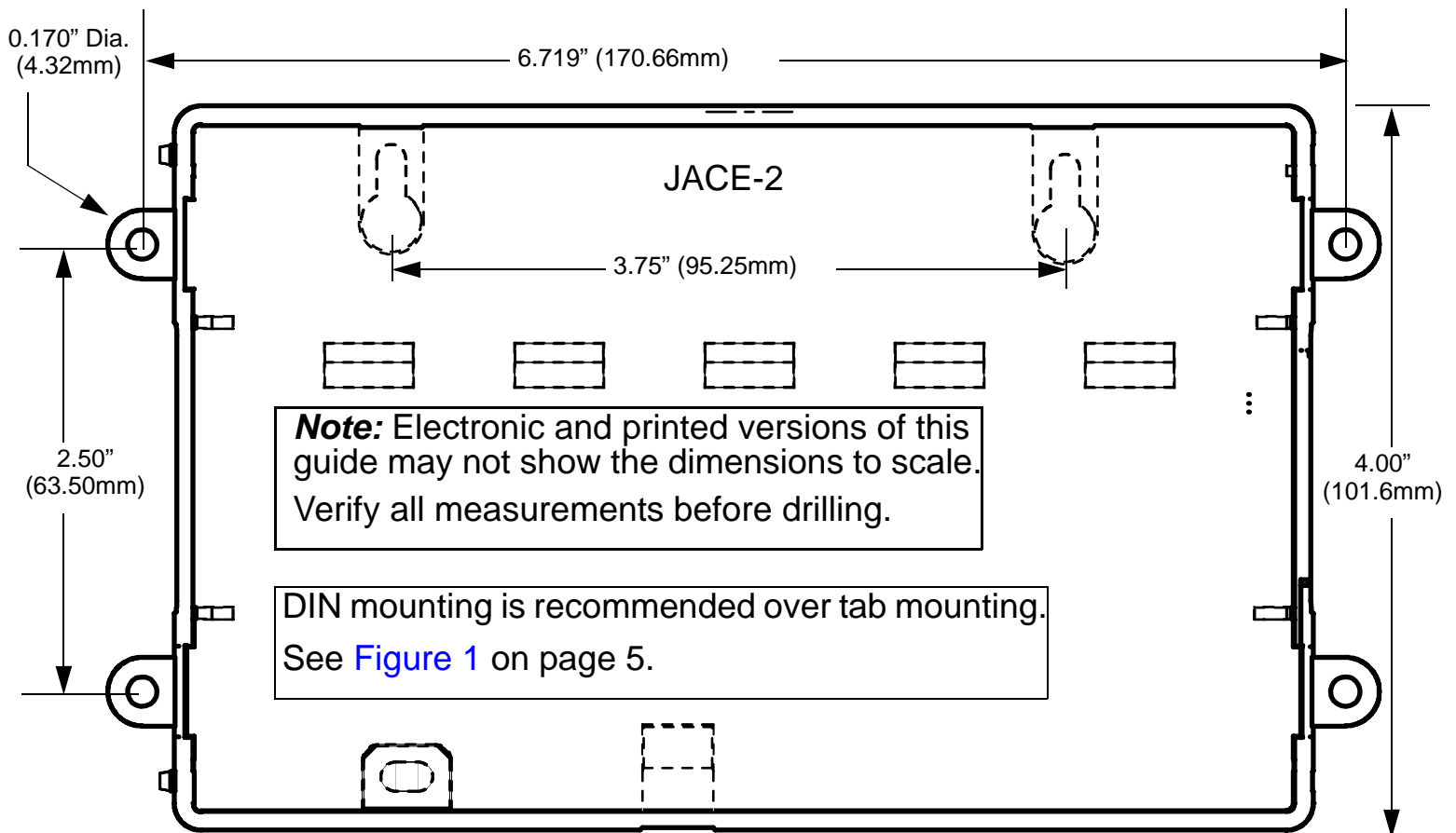

Distance between center of tabs from one unit to another unit.

Tip: If mounting accessory modules, future removal/replacement of the JACE-2 is simplified if you do **not** install screws in the "accessory module side" tabs of the JACE-2 (see above).

